

Customer Acknowledgment and Assumption of Responsibility for Modification to any Product.

Customer expressly acknowledges that modification of any equipment, machines, or other products purchased from Niagara Machine, Inc. ("Niagara"), including but not limited to DiamaPro Systems Products (collectively, "Products") through the attempted or actual use or misuse, adjustment, alteration, application of additional components, removal of provided components, repairs or attempted repairs by Customer (collectively, "Modifications") can lead to Product malfunction causing serious risks. Such risks include, but are not limited to, Product damage, bodily injury, death, or loss of or damage to property. Customer agrees that Customer is solely responsible for any Modifications Customer performs on any Product purchased from Niagara, and that Niagara is not responsible and will not be held liable for any claims, damages, or injury arising from Modifications by Customer, including Customer's employees, subcontractors, agents, representatives, affiliates, and assigns, to any Product purchased from Niagara. Customer further acknowledges and agrees that any Modification(s) to a Product may, at DiamaPro Systems' and/or Niagara's election, void any warranty applicable to the Product.

Customer agrees that, to the greatest extent permitted by law, Customer shall indemnify, hold harmless and, at Niagara's request, defend (with counsel reasonably approved by Niagara), Niagara, Niagara's parent, subsidiaries, affiliates and the officers, directors, employees and agents of Niagara (individually and collectively "Niagara Indemnitees") from and against, and pay or reimburse them for any and all third-party claims, losses, damages, liabilities, lawsuits and expenses (including reasonable attorneys' fees) relating to bodily injury, death, or loss of or damage to property caused by or arising from any Modification to a Product by Customer, its employees, subcontractors, agents, representatives, affiliates, and assigns (individually and collectively, "Customer Group"), with respect to the Products Customer purchases from Niagara.

Customer acknowledges that Customer has read and understands these terms, and voluntarily assumes full and sole responsibility for any and all effects arising from any Modification to a Product by Customer Group.



HGX-7 7" Angle Grinder



DiamaPro® Systems
3343 Peachtree Road NE
Suite 145 #24
Atlanta, GA 30326
470-977-2323

INSTRUCTION MANUAL

READ BEFORE OPERATING

ASSEMBLY VIEW

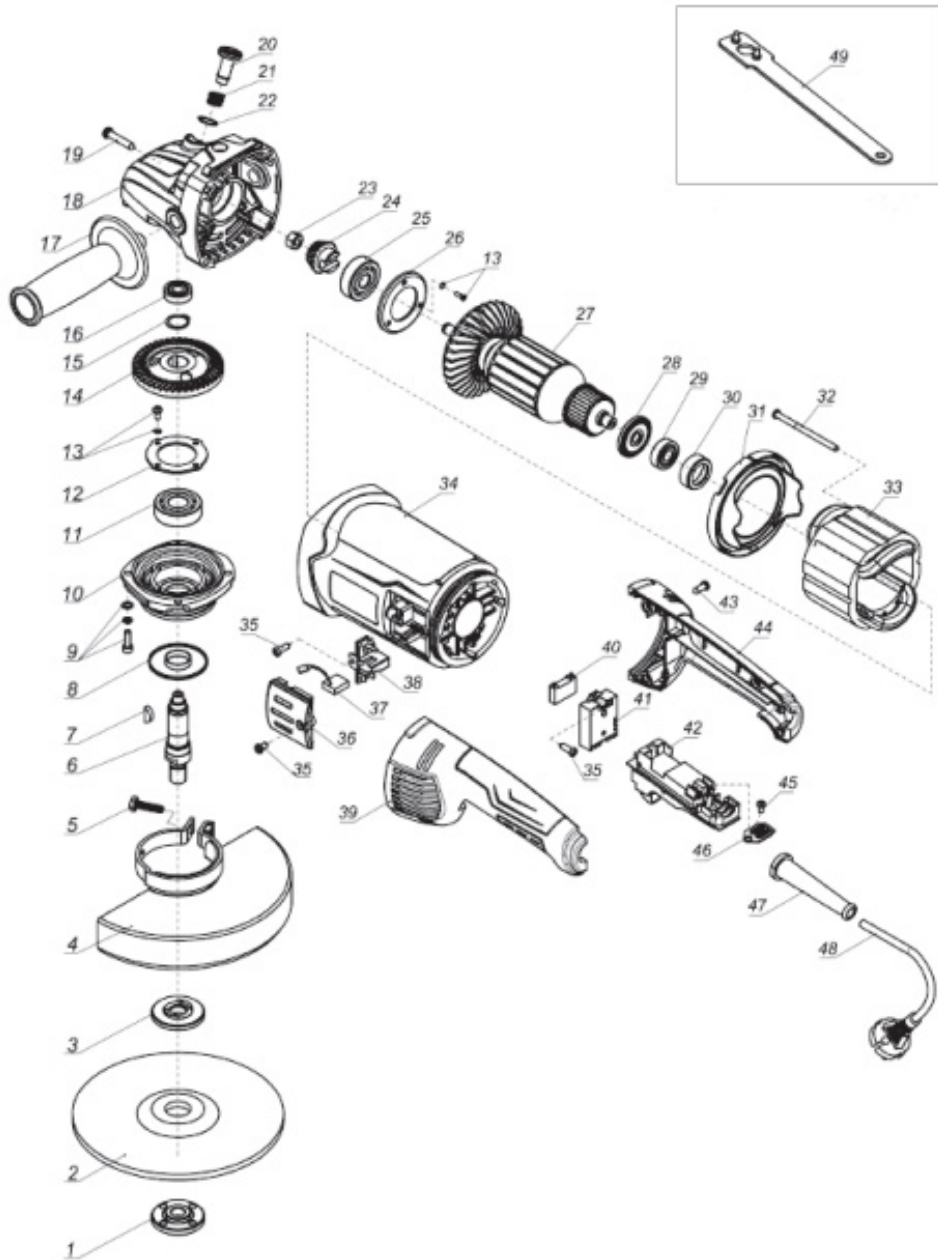

PARTS LIST

Part	Part No.	Description	Qty.
1 and 3	HGX-LOCKNUT	Lock Nut Set for Non-Threaded Cup Wheels	1
2	HGX-7-GRINDWHEEL	Grinding Wheel	1
4	HGX-7-WHEELCOVER	Wheel Cover	1
5	HGX-7-SCREWOHH	Outer Hexagon Head Screw	1
6	HGX-7-SPINDLE	Spindle	1
7	HGX-7-KEY	Key, 4x5x13	1
8	HGX-7-DUSTCOVER	Anti-Dust Cover	1
9	HGX-7-SCREWHSC	Hexagon Socket Cap Screw	4
10	HGX-7-BEARINGBOX	Bearing Box	1
11	HGX-7-BEARING6203	Bearing, 6203-2RS	1
12	HGX-7-BEARINGPLATE	Bearing Plate	1
13	HGX-7-SCREWCSHS	Cross Slotted Head Set Screw	7
14	HGX-7-BIGGEAR	Big Gear	1
15	HGX-7-RETAINER	Retainer 17	1
16	HGX-7-BEARING609	Bearing 609-2Z	1
17	HGX-7-SHANDLE	Side Handle	1
18	HGX-7-GEARBOX	Gear Box	1
19	HGX-7-SCREWCGDHST35	Cross Groove Disc Head Self Tapping Screw	4
20	HGX-7-LOCKPIN	Lock Pin	1
21	HGX-7-SPRING	Spring	1
22	HGX-7-WSPRING	Wire Spring 10	1
23	HGX-7-HEXNUT	Hexagon Nut	1
24	HGX-7-SMALLGEAR	Small Gear	1
25	HGX-7-BEARING6301	Bearing 6301-2RZ	1
26	HGX-7-BEARINGCLAMP	Bearing Clamp	1
27	HGX-7-ARMATURE	Armature Assembly	1
28	HGX-7-IWASHER	Insulation Washer	1
29	HGX-7-BEARING6000	Bearing 6000-2Z	1
30	HGX-7-BEARINGSLEEVE	Bearing Sleeve	1
31	HGX-7-WINDBAFFLE	Wind Baffle	1
32	HGX-7-SCREWCGDHST70	Cross Groove Disc Head Self Tapping Screw	2
33	HGX-7-STATOR	Stator Assembly	1
34	HGX-7-MOTORHOUSING	Motor Housing	1
35	HGX-7-SCREWCGDHST12	Cross Groove Disc Head Self Tapping Screw	6
36	HGX-7-BRUSHCOVER	Brush Cover	2
37	HGX-7-CARBONBRUSH	Carbon Brush	2
38	HGX-7-BRUSHHOLDER	Brush Holder Set	2
39	HGX-7-LHANDLE	Left Handle	1
40	HGX-7-CAPACITOR	Capacitor (0.33uf)	1
41	HGX-7-SSTART	Soft Start	1
42	HGX-7-SWITCH	Switch	1
43	HGX-7-SCREWCGDHST16	Cross Groove Disc head Self Tapping Screw	5
44	HGX-7-RHANDLE	Right Handle	1
45	HGX-7-SCREWCGDHST14	Cross Groove Disc head Self Tapping Screw	1
46	HGX-7-CABLECLAMP	Cord Clamp	1
47 and 48	HGX-7-CABLEPLUG	Cable with Plug and Cable Sleeve	1
49	HGX-7-WRENCH	Wrench	1

GENERAL SAFETY TOOLS

(For All Tools)

WARNING: Read and understand all instructions. Failure to follow all instructions listed below may result in electric shock, fire and/or serious personal injury.

Warning: The body of the machine may get warm after extended use. If this occurs, turn off the machine and let it cool down to avoid risk of damaging the unit, or personal injury.

SAVE THESE INSTRUCTIONS

WORK AREA

1. **Keep your work area clean and well lit.** Cluttered benches and dark areas invite accidents.
2. **Do not operate power tools in explosive atmospheres, such as in the presence of flammable liquids, gases or dust.** Power tools create sparks which may ignite the dust or fumes.
3. **Keep bystanders, children, and visitors away while operating a power tool.** Distractions can cause you to lose control.

ELECTRICAL SAFETY

4. **Power tool plugs must match the outlet. Never modify the plugs in any way. Do not use any adapter plugs with grounded power tools. Unmodified plugs and matching outlets will reduce risk of electric shock.** Do not change the plug in any way. Double insulation eliminates the need for the three wire grounded power cord and grounded power supply system.
5. **Avoid body contact with grounded surfaces such as pipes, radiators, ranges and refrigerators.** There is an increased risk of electric shock if your body is grounded.
6. **Do not expose power tools to rain or wet conditions.** Water entering a power tool will increase the risk of electric shock.

7. **Do not abuse the cord. Never use the cord to carry the tool or pull the plug from an outlet. Keep cord away from heat, oil, sharp edges or moving parts. Replace damaged cords immediately.** Damaged cords increase the risk of electric shock.
8. **When operating a power tool outside, use an outdoor extension cord marked “W-A” or “W.”** These cords are rated for outdoor use and reduce the risk of electric shock.

PERSONAL SAFETY

9. **Stay alert, watch what you are doing and use common sense when operating a power tool.** Do not use tool while tired or under the influence of drugs, alcohol, or medication. A moment of inattention while operating power tools may result in serious personal injury.
10. **Dress properly. Do not wear loose clothing or jewelry. Contain long hair. Keep your hair, clothing, and gloves away from moving parts.** Loose clothes, jewelry, or long hair can be caught in moving parts.
11. **Avoid accidental starting. Be sure switch is off before plugging in.** Carrying tools with your finger on the switch or plugging in tools that have the switch on invites accidents.

12. **Remove adjusting keys or wrenches before turning the tool on.** A wrench or a key that is left attached to a rotating part of the tool may result in personal injury.
13. **Do not overreach. Keep proper footing and balance at all times.** Proper footing and balance enables better control of the tool in unexpected situations.
14. **Use safety equipment. Always wear eye protection. Dust mask, non-skid safety shoes, hard hat, and hearing protection must be used for appropriate conditions.** Ordinary eye or sun glasses are NOT eye protection.

TOOL USE AND CARE

15. **Use clamps or other practical ways to secure and support the workpiece to a stable platform.** Holding the workpiece by hand or against your body is unstable and may lead to loss of control.
16. **Do not force tool. Use the correct tool for your application.** The correct tool will do the job better and safer at the rate for which it is designed.
17. **Do not use tool if switch does not turn it on or off.** Any tool that cannot be controlled with the switch is dangerous and must be repaired.
18. **Disconnect the plug from the power source before making any adjustments, changing accessories, or storing the tool.** Such preventative safety measures reduce the risk of starting the tool accidentally.

19. **Store idle tools out of the reach of children and other untrained persons.** Tools are dangerous in the hands of untrained users.
20. **Maintain tools with care. Keep cutting tools sharp and clean.** Properly maintained tools with sharp cutting edges are less likely to bind and are easier to control.
21. **Check for misalignment or binding of moving parts, breakage of parts, and any other condition that may affect the tool's operation.** If damaged, have the tool serviced before using. Many accidents are caused by poorly maintained tools.
22. **Use only proper 7” DiamoPro Systems tools with this model.** Accessories that may be suitable for one tool, may become hazardous when used on another tool.
23. **Tool service must be performed only by qualified repair personnel. Service or maintenance performed by unqualified personnel could result in a risk of injury.**
24. **When servicing a tool, use only identical replacement parts.** Follow instructions in the Maintenance section of the manual. Use of unauthorized parts or failure to follow maintenance instructions may create a risk of electric shock or injury.
25. **Always use with a DiamoPro Systems dust shroud.**
26. **Failure to follow proper use guidelines will result in void of warranty.**

SPECIFIC SAFETY RULES

DO NOT let comfort or familiarity with product (gained from repeated use) replace strict adherence to grinder safety rules. If you use this tool unsafely or incorrectly, you can suffer serious personal injury.

1. **Always use a DiamoPro Systems dust shroud.** Shrouds protect operator from broken wheel fragments.
2. **Accessories must be rated for at least the speed recommended on the tool warning label.** Wheels and other accessories running over rated speed can fly apart and cause injury.
3. **Do not let the tool come in contact with live wire.** Contact with a "live" wire will make exposed metal parts of the tool "live" and shock the operator.
4. **Always use safety glasses or goggles. Ordinary eye or sun glasses are NOT safety glasses.**
5. **Check the wheel carefully for cracks or damages before operation.** Replace cracked or damaged wheel immediately. Run the tool (with guard) at no load for about a minute, holding tool away from others. If wheel is flawed, it will likely separate during this test.
6. **Only use with DiamoPro Systems 7" cupwheels and abrasives.**
7. **Be careful not to damage the spindle, the flange (especially the installing surface) or the outer flange.** Damage to these parts could result in wheel breakage.
8. **NEVER use tool with wood cutting blades or other saw blades.** Such blades when used on a grinder frequently kick and cause loss of control leading to personal injury.
9. **Hold the tool firmly.**
10. **Keep hands away from rotating parts.**
11. **Make sure cord is clear of wheel.** Do not wrap cord around your arm or wrist. If control of tool is lost, cord may become wrapped around you and cause personal injury.
12. **Make sure the wheel is not contacting the workpiece before the switch is turned on.**
13. **Before using the tool on an actual workpiece, let it run for a while.** Watch for vibration or wobbling that could indicate poor installation or a poorly balanced wheel.
14. **Use the specified surface of the wheel to perform the grinding.**
15. **Watch out for flying sparks.** Hold the tool so that sparks fly away from you and other persons or flammable materials.
16. **Do not leave the tool running.** Operate the tool only when hand-held.
17. **Do not touch the workpiece immediately after operation; it may be extremely hot and could burn your skin.**
18. **ALWAYS wear proper apparel including long sleeve shirts. Leather gloves and shop aprons to protect skin from contact with hot grindings.**
19. **Use of this tool to grind or sand some products. Paints and wood could expose user to dust containing hazardous substances. Use appropriate respiratory protection.**
20. **Must use with DiamoPro Hepa Filtered Dust Collector**

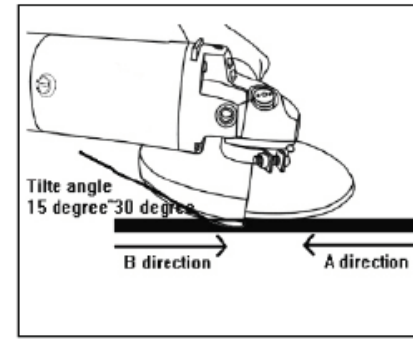

Fig7

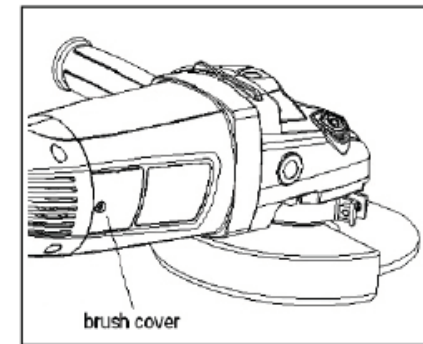

Fig8

■ Effective and safe grinding & sanding operation.

- Always hold the tool firmly with one hand on housing and the other on the side handle. Turn the tool on and then apply the wheel or disc to the workpiece.
 - Operating the tool while removing the wheel guard is forbidden.
1. Do not place too much pressure on the tool. Excessive strength could damage the tool engine and abrasive wheel due to overload.

■ Replacing carbon brushes.

1. Remove and check the carbon brushes regularly. Replace when the tool sparks or wears down with 5-7mm left.
2. Both carbon brushes should be replaced at the same time. Use only DiamoPro Systems brushes.
3. Please send this tool to DiamoPro Systems' authorized service center to replace or be repaired by an experienced technician.

■ Maintenance & Daily Care.

CAUTION:

Always be sure that the tool is switched off and unplugged before attempting to perform inspection and maintenance.

1. The tool and its air vents have to be kept clean. Regularly clean the tool's air vents, or whenever the vents start to become obstructed.
2. Make sure all screws are properly tightened.
3. Regularly check if the cord insulation is broken.

△ CAUTION:

Be sure to reinstall the knob after inserting new carbon brush. After replacing brushes, plug in the tool and break in brushes by running tool with no load for ~10min. If the tool is not working well, ask your local DiamoPro Systems service center for repair.

To maintain product SAFETY & RELIABILITY, repairs and other maintenance or adjustment should be performed by DiamoPro Systems Authorized or Factory service centers, always using DiamoPro Systems replacement parts.

SAVE THESE INSTRUCTIONS

WARNING: MISUSE or failure to follow the safety rules stated in this instruction manual may cause serious personal injury.

FUNCTIONAL DESCRIPTION

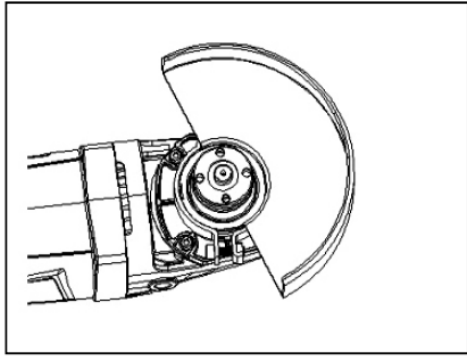

Fig1

■ Operation Instructions:

◆ Wheel Guard

Aim the convex end of the wheel guard to the slot mouth of the front cover, and then rotate the guard body to 180°, finally tighten the fastening screw (Fig1 & Fig2).

◆ Installing or removing grinding wheel

△ CAUTION:

- When using an abrasive cut-off wheel, be sure to use only the supplied wheel guard, inner flange, and outer flange designed for use with cut-off wheels.

1. Mount the inner flange onto the spindle. Fit the wheel/disc on the inner flange and screw the outer flange onto the spindle (Fig 3).
2. To tighten the outer flange, press the shaft lock firmly so that the spindle cannot revolve, then use the lock nut wrench and securely tighten clockwise (Fig 4).
3. To remove the wheel, follow the installation procedure in reverse.

❖ NOTICE:

The groove of INNER FLANGE must align the flatness of spindle when you install the wheel and tighten enough.

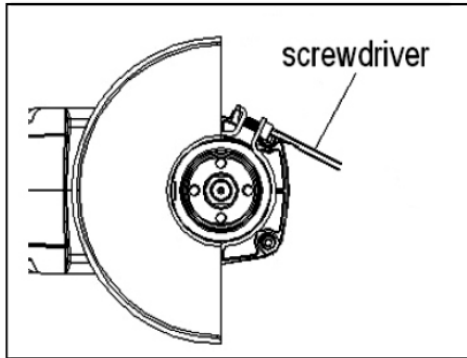

Fig2

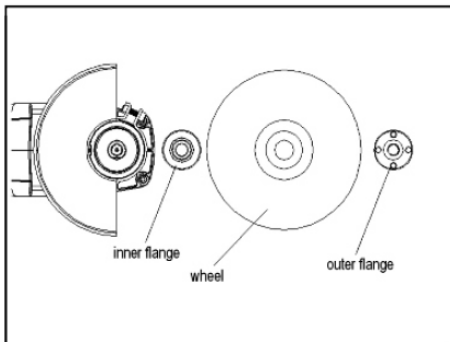

Fig3

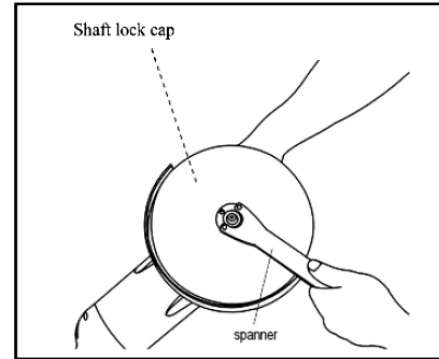

Fig4

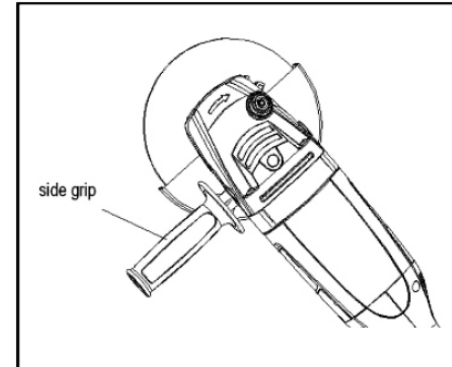

Fig5

◆ Side grip (Fig 5).

△ CAUTION:

Always be sure that the side grip is installed securely before operation. Screw the side grip securely on the position of the tool as shown in Fig5. Hold the side grip firmly by hand to better control the tool.

◆ Switch Action (Fig 6).

△ CAUTION:

- Before plugging in the tool, always check to see that the switch trigger actuates properly and returns to the "OFF" position when released.
- Switch cannot be locked in "ON" position for safety of operator during use. Apply caution when using tool and maintain firm grasp on tool.

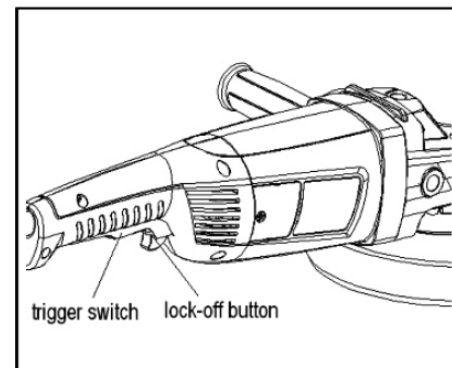

Fig6