



**Diamapro**<sup>®</sup>  
SYSTEMS

## **OWNER'S MANUAL**

# **AS-500**

## **AIR SCRUBBER**



### **USER & MAINTENANCE BOOK**

SAVE THESE INSTRUCTIONS FOR FUTURE REFERENCE



# WARRANTY REGISTRATION CARD

Form must be completed and submitted within 30 days from the date of purchase.

## Customer Information

First and Last Name

Company Name

Address

City

State

Zip Code

Phone Number

Email

## Machine Information

Machine Type

Machine Model

Serial #

Purchase Date (dd/mm/yy)

Diamapro® Systems  
3343 Peachtree Road NE  
Suite 145 #24  
Atlanta, GA 30326

## SPECIFICATIONS

Part No. AS-500

Power 110-120 Vac, 1.9 amps

Blower 500 CFM

Filters: 1st stage 1" Pleated Media, 2nd stage 2.5" Pleated HEPA 18" x 18"

Dimensions Width 22"

Height 14"

Depth 24"

Weight 33 lbs.

## IMPORTANT SAFETY INSTRUCTIONS

### **CAUTION**

***CAUTION: Risk of electric shock. Can cause injury or death. To reduce the risk of electric shock:***

Do not expose to standing water or rain

Connect to GFCI outlet

Do not use an extension cord

Unplug fan before servicing or changing filters.

Do not block air intake or outlet. One foot minimum distance to obstructions.

Indoor use only

Do not use as stool or bench

Do not operate with damaged cord or plug.

Do not run cord under carpeting. Do not cover cord with throw rugs, runners, or similar coverings.

Do not route cord under furniture or appliances. Arrange cord away from traffic area and where it will not be tripped over.

### Transporting the AS-500

AS-500 should be transported vertically or horizontally on the appropriate feet located on the bottom of the unit or opposite the handle.

### Electrical Requirements

The AS-500 can be plugged into a grounded 15 Amp circuit. It draws about 2 Amps with clean filters and no ducting. The amp draw will decrease slightly with added ducting and as the filters load with particulate. Due to the presence of GFCI receptacle, the AS-500 model must be plugged directly into a wall outlet. No extension cords should be used.

### *Air Ducting*

Always turn off unit prior to attaching air ducting.

#### A. Inlet Ducting

Occasionally the area to be filtered is difficult to access and/ or the unit cannot be located in the area. In such cases, the air can be ducted to the unit's inlet. A round 16" diameter flexible duct can be attached to the unit inlet. It connects by placing the wire in the duct over the duct collar lip at one location and working over it over the lip gradually. It may be removed after use for easier transport and storage.

#### B. Outlet Ducting

A detachable trapezoid shaped exhaust ring is supplied that will allow 10" round lay-flat plastic duct to be attached to the AS-500 outlet. To attach ducting to the collar, remove the ring from the unit by pressing release tab at the top of the grill. Put the plastic duct end through the inside of the ring. Roll the duct end outward so that it over-laps the outside of the ring. Clip the ring back onto the exhaust grill.

#### C. Negative Air Ducting

The AS-500 can be used to filter and exhaust air from a space. When exhausting to outside the space, the space will be under a slight negative pressure. This will help prevent airborne particles from leaving the space, because the negative pressure will draw air in through openings in the space's exterior surfaces.

### Resettable Circuit Breaker

The 12 AMP thermal response resettable circuit breaker protects the unit and devices connected to its duplex GFCI outlet.

The circuit breaker is designed to sense the total current draw through the circuit. The circuit breaker “trips” when more than 12 amps of electrical current are drawn through the device’s power cord. Should an over-current condition occur, AS-500 on-board circuit breaker prevents nuisance visits to a remote power junction box.

### IMPORTANT

***IMPORTANT: Total amperage of the AS-500 plus all devices plugged into the receptacle must not exceed 12 amps. The circuit breaker will not allow for loads in excess of 12 amps, although there is a time delay before the overloaded circuit is broken.***

### IMPORTANT

***IMPORTANT: When the DiamaPro® AS-500 is plugged into a standard “powered” wall outlet the DiamaPro® AS-500’s duplex outlet is electrically “HOT” and AC voltage is present.***

### GFCI Protection and the On-Board Duplex VAC Outlet

The standard AC voltage outlet GFCI (Ground Fault Circuit Interrupter) protection promotes operator safety in wet applications. GFCI devices trip when a fault to electrical “ground” is sensed.

It is recommended to check the GFCI protection prior to operation. To check, push the “TEST” button located on the GFCI duplex outlet. If operating properly the “RESET” button on the GFCI outlet will pop out. A tripped GFCI is indicated by a small LED. The device can only be “RESET” when AS-500 is connected to a wall outlet providing standard voltage. This duplex AC outlet allows the inter-connection of other AC powered devices. The sum total amperage of all devices plugged into the receptacle must not exceed 10 amps.

### Servicing

Before each use inspect for damage, blocked inlet or outlet.

Inspect the GFCI to ensure it is not in a “tripped” condition. Push “RESET” to reset the GFCI. When the AS-500 is first turned on, check for excessive vibration. If the unit vibrates excessively or if impeller rubs on housing, turn off the unit immediately. Have a service technician inspect the unit to locate the problem.

## OPERATION

### **CAUTION**

***CAUTION: Exhausting too much air from a space with open combustion devices (E.g. furnace, fireplace or water heater) can cause those devices to backdraft. This can contaminate the space with potentially fatal gases.***

In such cases, the AS-500 must be used in one of the following three ways:

- A. As a filtering unit only. Exhausting no air from the space and thus causing no negative pressure or backdrafting.
- B. Exhausting a very limited amount of air which does not cause backdrafting. In case B, the open combustion devices must be thoroughly checked to guarantee that they do not backdraft while the AS-500 is running.
- C. Direct the outlet duct from AS-500 to the room with the open combustion device(s). This will positively pressurize the room with HEPA filtered air, thus preventing backdrafting. As in case B, those combustion devices must be checked after AS-500 is running to guarantee that they are not backdrafting.

## Power/Speed Control

The power/speed switch is located on the control panel. When turned on to any speed, it powers the impeller fan.

Occasionally the impeller fan may not start on low speed. If this occurs, rotate the speed control to high speed until the impeller fan starts, then adjust it to a lower speed.

### **CAUTION**

***CAUTION: Do not remove HEPA filter or exhaust ring guard with the unit on. Removing the top and filters while running will expose the dangerous rotating impeller fan. Disconnect the appliance before changing filters.***

## WARNING

***Use extreme caution when changing the HEPA filter as hazardous material could be trapped in the media. Always make sure to dispose of filters in the appropriate way. If you are unsure of how to safely dispose of any filter-consult an industrial hygienist to ensure that all hazardous materials are contained and disposed of properly.***

## Air Filters

The standard AS-500 HEPA System is equipped with two filters that progressively filter out smaller particles. These filters must be checked regularly. Operating the unit with dirty filters will reduce the airflow, but will do no harm to the unit. The unit can be run indefinitely with dirty filters.

The two standard filters used are listed below (as installed in the unit from top to bottom):

- A. Pre-filter.
- B. HEPA filter.

## Filter replacement

A

When the amber “filter change light” illuminates. It may be time to replace one or both filters.

To check airflow accurately, an airflow meter or anemometer must be used:

- When the filter change light illuminates; remove all ducting and run on high speed. If the filter light remains lit; replace the pre-filter and run on high again. If the light remains; it is time to replace the HEPA filter for full 500 CFM performance.

The operator must judge if that is acceptable.

If the operator determines the filters should be changed due to low airflow, change them in the following order:

Change the pre-filter (top) first.

Recheck the airflow. If the airflow is acceptable, no other filters need to be changed.

If the airflow is still too low, the HEPA filter must be changed.

To remove the HEPA filter, follow these steps:

1. Loosen the eight screws one revolution
2. Rotate all eight clips out of the way.
3. Remove old filter.
4. Installing the new filter is the reverse of these instructions

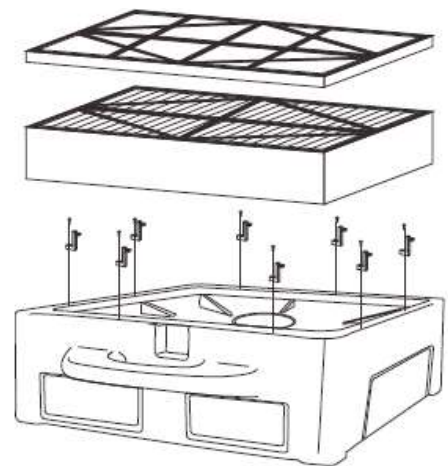

# REPLACEMENT PARTS

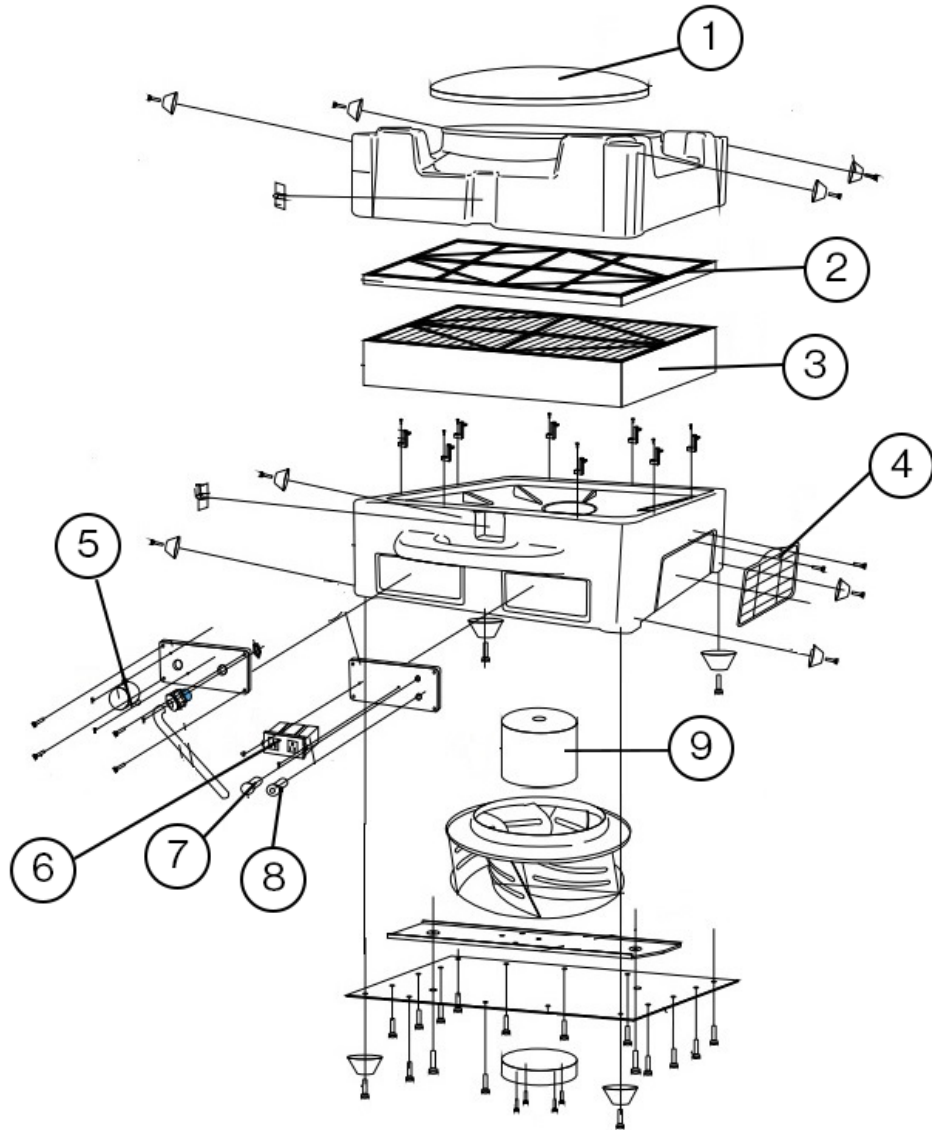

ITEM NO.	PART NUMBER	DESCRIPTION	QTY.
1	DP-AS-500-RFMCP	Removable Foam Cap for DiamoPro AS-500	1
2	DP-AS-500-PFLTR	Pre-filter for DiamoPro AS-500	1
3	DP-AS-500-HEPA	HEPA Filter for DiamoPro AS-500	1
4	DP-AS-500-AOSCRN	Air Outlet Screen for DiamoPro AS-500	1
5	DP-AS-500-PWRSWTCH	Power Switch for DiamoPro AS-500	1
6	DP-AS-500-OTLT	GFCI Outlet for DiamoPro AS-500	1
7	DP-AS-500-CBRKR	Circuit Breaker for DiamoPro AS-500	1
8	DP-AS-500-FCLGHT	Filter Change Light for DiamoPro AS-500	1
9	DP-AS-500-MTR	Motor for DiamoPro AS-500	1
NP	DP-AS-500-PFLTR-C	Charcoal Pre-filter for DiamoPro AS-500	1



## **Customer Acknowledgment and Assumption of Responsibility for Modification to any Product.**

Customer expressly acknowledges that modification of any equipment, machines, or other products purchased from Niagara Machine, Inc. ("Niagara"), including but not limited to DiamaPro Systems Products (collectively, "Products") through the attempted or actual use or misuse, adjustment, alteration, application of additional components, removal of provided components, repairs or attempted repairs by Customer (collectively, "Modifications") can lead to Product malfunction causing serious risks. Such risks include, but are not limited to, Product damage, bodily injury, death, or loss of or damage to property. Customer agrees that Customer is solely responsible for any Modifications Customer performs on any Product purchased from Niagara, and that Niagara is not responsible and will not be held liable for any claims, damages, or injury arising from Modifications by Customer, including Customer's employees, subcontractors, agents, representatives, affiliates, and assigns, to any Product purchased from Niagara. Customer further acknowledges and agrees that any Modification(s) to a Product may, at DiamaPro Systems' and/or Niagara's election, void any warranty applicable to the Product.

Customer agrees that, to the greatest extent permitted by law, Customer shall indemnify, hold harmless and, at Niagara's request, defend (with counsel reasonably approved by Niagara), Niagara, Niagara's parent, subsidiaries, affiliates and the officers, directors, employees and agents of Niagara (individually and collectively "Niagara Indemnitees") from and against, and pay or reimburse them for any and all third-party claims, losses, damages, liabilities, lawsuits and expenses (including reasonable attorneys' fees) relating to bodily injury, death, or loss of or damage to property caused by or arising from any Modification to a Product by Customer, its employees, subcontractors, agents, representatives, affiliates, and assigns (individually and collectively, "Customer Group"), with respect to the Products Customer purchases from Niagara.

Customer acknowledges that Customer has read and understands these terms, and voluntarily assumes full and sole responsibility for any and all effects arising from any Modification to a Product by Customer Group.



**DiamaPro**<sup>®</sup>  

---

**SYSTEMS**

DiamaPro<sup>®</sup> Systems  
3343 Peachtree Road NE  
Suite 145 #24  
Atlanta, GA 30326  
470-977-2323